



15lt & 30lt

Talsa Bowl Cutters



K15neo, K30neo: advantages at a glance



- 7" digital touch screen displaying knife speed, temperature, elapsed time and current time.
- Variable speed control 700 to 3.000 rpm and 4 speed preselection buttons.
- Programmable automatic stop triggered by temperature limit and/or elapsed time
- Smooth start of knives due to electronic drives, overload protection.
- Low consumption motor + drive = high efficiency.
- Emergency stop button.
- Removable 3-knife head, optionally with 6 knives.
- High quality BE-GW Steffens (Germany) knives.
- Strong, all stainless steel construction, solid s/s bowl and lid.
- Easy access maintenance covers. Adjustable, non-slip and vibration absorbing machine feet.
- Knife lid assisted with pneumatic piston (K30neo), automatic stop of the knives when opening lid.
- Transparent noise protection cover.
- Temperature sensor C/F located in cavity of lid: precise temperature measurement of mix during operation.
- Removable friction lid/bowl band for easy cleaning, with self-adjusting springs.
- Electric device to prevent condensations inside the machine frame.
- High quality, silent Poly-V drive belt.
- All screws stainless steel.
- IP65 watertight electric cabinet (K30neo).
- Bottom of machine closed.
- Easy cleaning.



7" digital touch screen.



Solid cast stainless steel bowl.
CNC precision machining.



Removable knife head with
3 knives (standard).



Optional 6-knife head.



Removable, self-adjusting
friction lid/bowl band.



Transparent noise protection cover.

Technical data



K15neo



K30neo

Technical specifications		K15neo	K30neo
Bowl capacity		15 liters (4 gallon)	30 liters (8 gallon)
Approximate batch size	soft mix	± 4-12 kg (± 9-26 lbs)	± 5-22 kg (± 11-48 lbs)
	tough mix	± 4-8 kg (± 9-18 lbs)	± 5-15 kg (± 11-33 lbs)
Machine power		2.3 kW / 3 HP	5.6 kW / 7.5 HP
Electric power type		single-phase	three-phase
Max. consumption	220/230 V	22.5 A	22.9 A
	380/400 V	-	13.2 A
Knife speed	variable	750 to 3,000 rpm	
	preselect-buttons	750 / 1,500 / 2,250 / 3,000 rpm	
Linear knife speed		9-37 m/s	12-48 m/s
Net weight approx.		± 165 kg (± 364 lbs)	± 330 kg (± 728 lbs)
Sound pressure level at 1 m		± 68 dB(A)	± 71 dB(A)
Operating temperature		+5° to +40° C (40° to 105° F)	
Recommended relative humidity level		20 to 90 %	

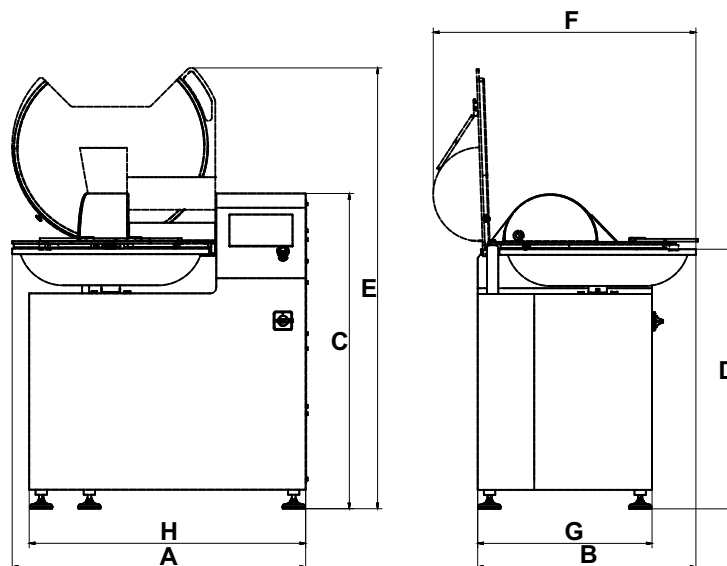

Dimensions cm (inches)	K15neo	K30neo
A	87 (34")	104 (41")
B	63 (25")	77 (31")
C	56 (22")	112 (44")
D	40 (16")	92 (36")
E	92 (36")	156 (62")
F	75 (30")	93 (37")
G	50 (20")	62 (24")
H	78 (31")	98 (39")
Packaging	102x78x75 (36x25x22")	118x104x133 (101x31x45")
Volume	0.6 m ³	1.6 m ³

Important advice: always choose large bowl cutter capacity and power, to allow the future growth of production. Available Talsa capacities: 15, 30, 50, 80, 120 and 200 liters.