

Meat Processing Equipment

Viking PM32 Mixer Mincer

Made and designed in Europe - the Viking PM models are an extremely durable range of mixer mincers with well thought out additional features making it one of Australia's popular unit amongst butchers, and meat processing facilities.

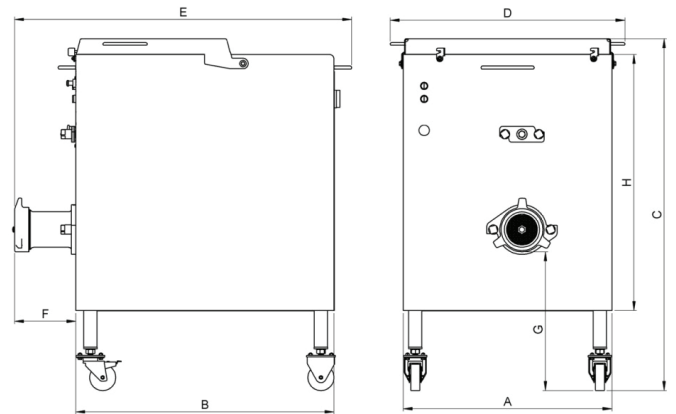

A	670mm	E	1,190mm
B	900mm	F	220mm
C	1,325mm	G	610mm
D	770mm	H	890mm

VIKING PM32 MIXER MINCER

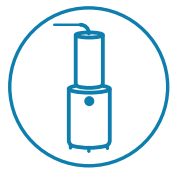

Polished Finish



Removable Paddle & Barrel

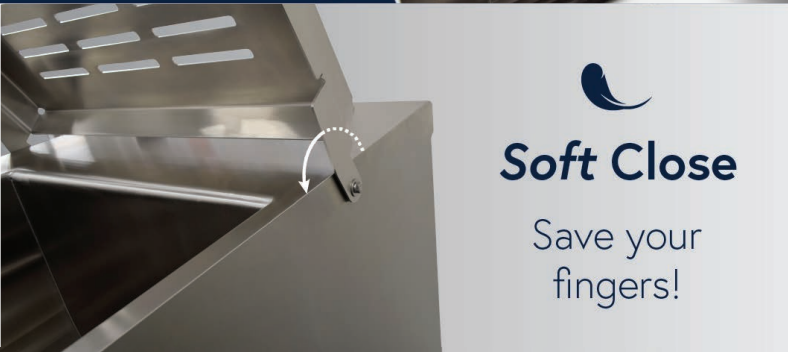

Soft Close
Save your fingers!



Reversing Feed Screw



VIKING PM32

Cutting Size	#32
Output	700kg per hour
Power Supply	3 Phase 415V/ 20A
Dimensions (WxDxH)	770 x 1050 x 1325mm (excl. barrel)
Load Height	1100mm
Optional	Interlocking Safety Guard, Foot Pedal

Features and Benefits

- Removable Barrel
- Soft-closing Lid System
- Auto-reverse Mixing Paddles
- Removable Mixing Paddle
- Polished Finish
- Automatic Feeding

1300 88 99 51
sales@vikingfoodsolutions.com.au

www.vikingfoodsolutions.com.au



EQUIPPING THE FOOD INDUSTRY TO GROW