

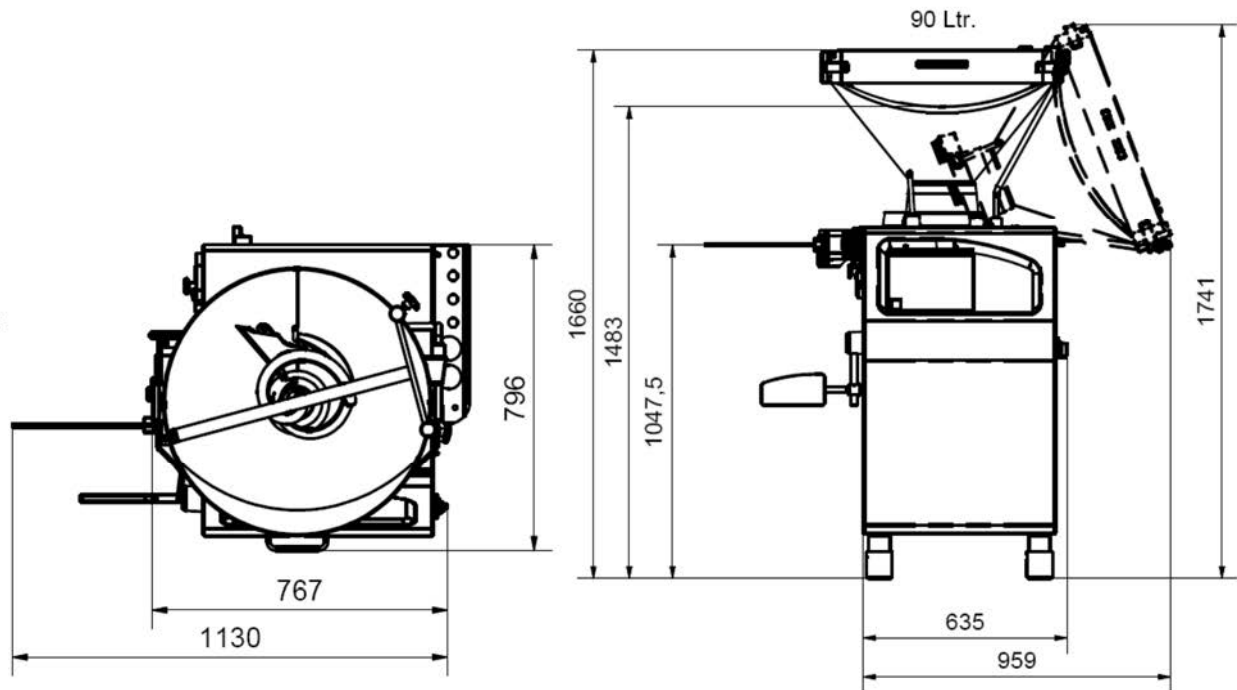

The Rex 327 model Vacuum Filler is an extremely versatile machine, suitable for filling a wide range of individual requirements and processing various types of liquids or viscous substances.

- Perfect for small to large enterprises with frequently changing product
- Reliable, quick and easy cleaning
- Efficient energy running costs
- Guaranteed gentle transport of all filling substances
- Reliability through Quality
- Simple to operate Touch Screen



FEATURES

- Colour touch screen control panel
- Power regulated electronic servo drive – Maintenance free! (not oil Hydraulic).
- 90L Hopper
- Rotary Vane pump with 4 vanes (8 chambers).
- Programmable computer control panel with 99 filling programs.
- Maximum portioning precision, infinitely adjustable.
- Linking drive integrated into discharge (thus minimal residual product)
- Exceptionally quiet, due to electronic servo drive.
- All stainless steel, self supporting machine housing.
- Holding bracket for nozzles and accessories.
- Product draw back function.
- Chamber drain plug for easy cleaning.
- Adjustable hopper tipping height for operator convenience
- Inbuilt vacuum pump (21cbm).
- Pressure gauge for vacuum system, & pressure adjustment.
- Maximum filling capacity 2,700kg p/hr.
- Maximum pressure 40 bar.
- Portioning speed 350 pcs / min (40gr portions).
- Portioning weight 1 to 99,999g.
- Standard filling nozzles 25 & 40mm.
- Clipper outlet socket, for clipper, hamburger patti, cevapi cutter & meat ball attachments.

SPECIFICATIONS

- 90L Hopper capacity
- 5kW Power rating

OPTIONAL

- Linking device