

# 250 300 330

# 350 385



Viking Slicers  
The Ultimate Slicing Experience



The Viking 350 Slicer  
pictured is the ultimate in  
superior quality and design.

# SLICERS FOR PROFESSIONALS



# 250B 300B

## VIKING 250 BELT DRIVEN SLICER

Blade Size	250mm ø
Hopper Dimensions	230 x 230 mm
Cutting Thickness	1-13mm
Power Supply	240V - 50Hz
Type	Belt Driven

### Machine Dimensions (See diagram below)

A	395mm
B	245mm
C	500mm
D	560mm
E	370mm
F	570mm
G	475mm

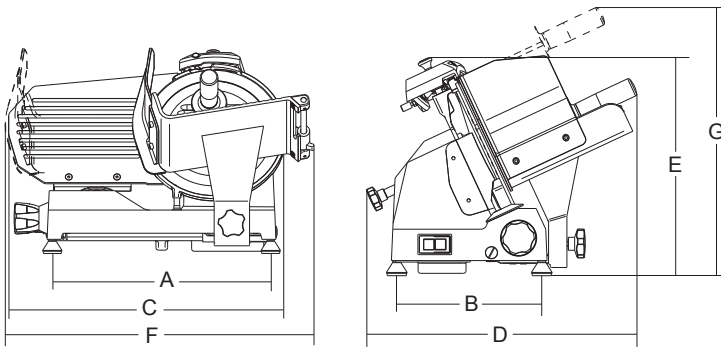

## VIKING 300 BELT DRIVEN SLICER

Blade Size	300mm ø
Hopper Dimensions	250 x 275 mm
Cutting Thickness	1-13mm
Power Supply	240V - 50Hz
Type	Belt Driven

### Machine Dimensions (See diagram below)

A	435mm
B	295mm
C	600mm
D	610mm
E	420mm
F	640mm
G	510mm

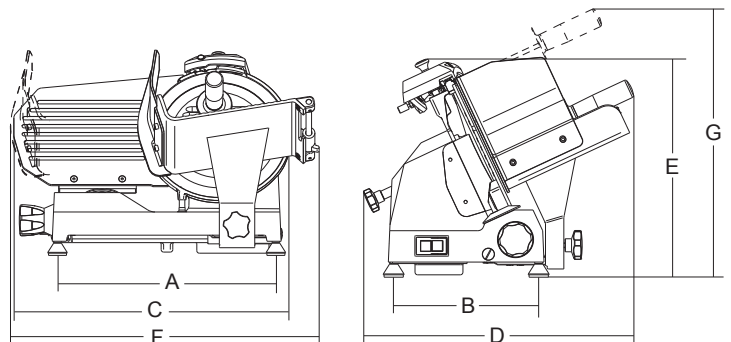

# 330B 330G 330A



## VIKING 330 BELT DRIVEN SLICER

Blade Size	330mm $\varnothing$
Hopper Dimensions	305 x 270 mm
Cutting Thickness	1-30mm
Power Supply	240V - 50Hz
Type	Belt Driven

Machine Dimensions (See diagram below)

A	465mm
B	340mm
C	645mm
D	570mm
E	455mm
F	710mm
G	535mm

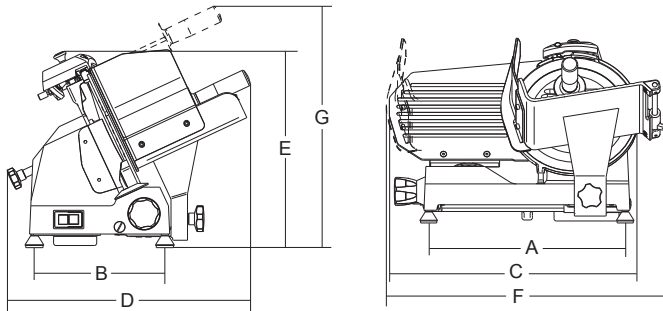

## VIKING 330 GEAR DRIVEN SLICER

Blade Size	330mm $\varnothing$
Hopper Dimensions	305 x 270 mm
Cutting Thickness	1-30mm
Power Supply	240V - 50Hz
Type	Gear Driven



## VIKING 330 AUTO SLICER

Blade Size	330mm $\varnothing$
Hopper Dimensions	365 x 270 mm
Cutting Thickness	1-30mm
Power Supply	240V - 50Hz
Type	Belt Driven
Other	Slice Counter
Operation	Auto/Manual

Machine Dimensions (See diagram below)

A	465mm
B	340mm
C	645mm
D	660mm
E	455mm
F	730mm
G	650mm

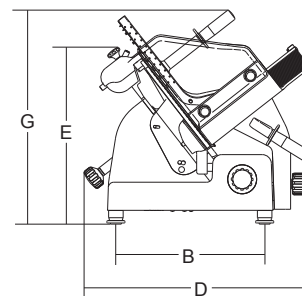
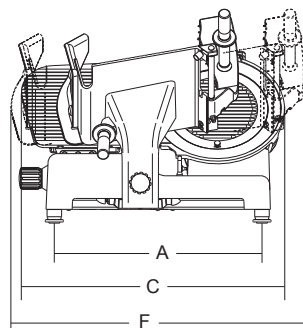

# 350B 350G

## VIKING 350 BELT DRIVEN SLICER

Blade Size	350mm $\phi$
Hopper Dimensions	350 x 320 mm
Cutting Thickness	1-30mm
Power Supply	240V - 50Hz
Type	Belt Driven

### Machine Dimensions (See diagram below)

A	575mm
B	410mm
C	730mm
D	680mm
E	520mm
F	800mm
G	700mm

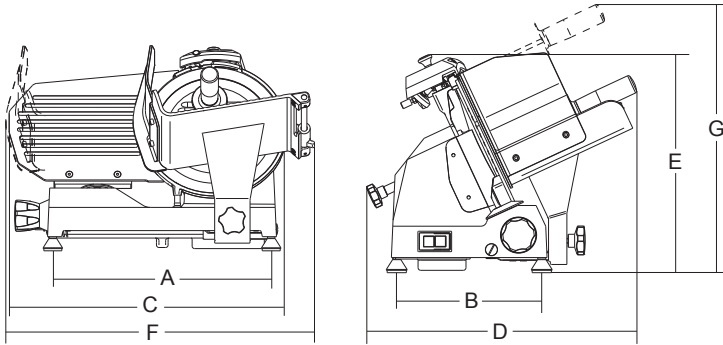

## VIKING 350 GEAR DRIVEN SLICER

Blade Size	350mm $\phi$
Hopper Dimensions	350 x 320 mm
Cutting Thickness	1-30mm
Power Supply	240V - 50Hz
Type	Gear Driven

### Machine Dimensions (See diagram below)

A	575mm
B	410mm
C	760mm
D	732mm
E	515mm
F	816mm
G	700mm

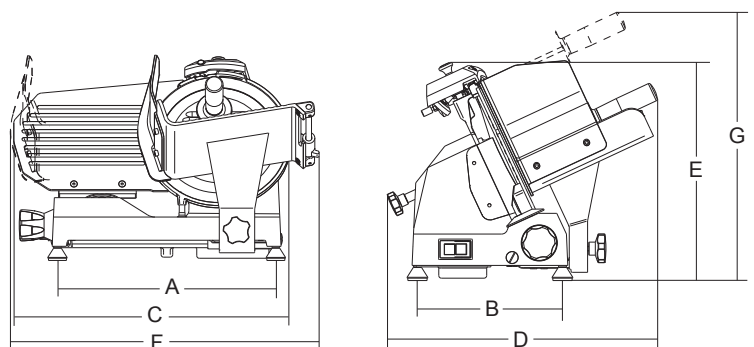



“The quality of my slicer is so important to me – and the Viking is the best slicer I have ever used!”

# 350V 385A

## VIKING 350 VERTICAL SLICER

Blade Size	350mm ø
Hopper Dimensions	430 x 300 mm
Cutting Thickness	1-30mm
Power Supply	240V - 50Hz
Type	Belt Driven
Other	Fresh Meat Slicer

Machine Dimensions (See diagram below)

A	575mm
B	410mm
C	740mm
D	720mm
E	600mm
F	840mm
G	640mm

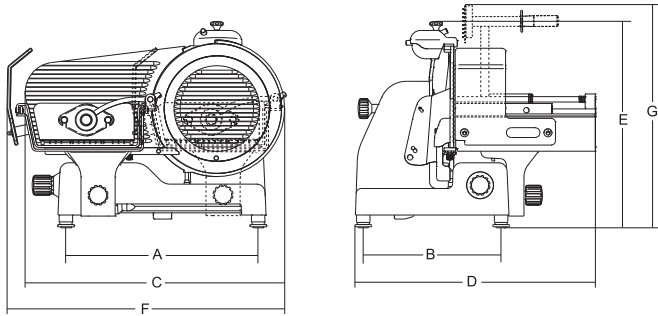

## VIKING 385 AUTO SLICER

Blade Size	385mm ø
Hopper Dimensions	430 x 320 mm
Cutting Thickness	1-30mm
Power Supply	240V - 50Hz
Type	Belt Driven
Other	Slice Counter
Operation	Auto/Manual

Machine Dimensions (See diagram below)

A	575mm
B	410mm
C	760mm
D	732mm
E	515mm
F	816mm
G	730mm

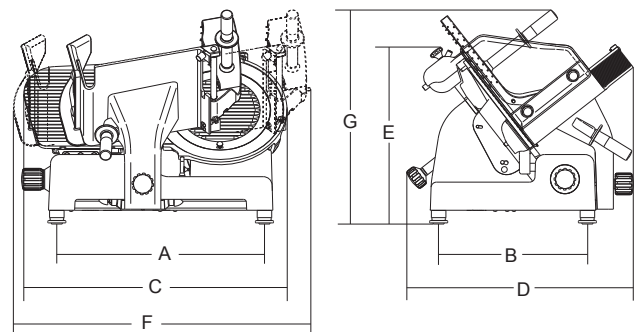



BMSS Pty Ltd - Incorporating Viking Food Solutions  
T 1300 88 99 51 | [www.bmss.com.au](http://www.bmss.com.au)

DEALER

Viking Slicers  
The Ultimate Slicing Experience

